



PIPELINE ANCILLARIES

SAFETY VALVE | PRESSURE REDUCING VALVE (PRV) | EXPANSION JOINT | STEAM TRAP | BLOW DOWN VALVE

Safety Valve

A safety valve is a safety device designed to protect a pressurized vessel or system during an overpressure event. An overpressure event refers to any condition which would cause pressure in a vessel or system to increase beyond the specified design pressure or maximum allowable working pressure (MAWP).

Pressure-reducing Valve (PRV)

Pressure-reducing valve provide a steady pressure into a part of the system that operates at a pressure lower than normal system pressure. A reducing valve can normally be set for any desired downstream pressure within its design limits. Once the valve is set, the reduced pressure will be maintained regardless of changes in the supply pressure and system load variations.

Expansion Joint

Expansion joints are used in piping systems to absorb thermal expansion or terminal movement where the use of expansion loops is undesirable or impractical. Expansion joints are available in many different shapes and materials.

Steam Trap

A steam trap is a device used to discharge condensates and non-condensable gases with a negligible consumption or loss of live steam. Most steam trap are nothing more than automatic valve. They open, close or modulate automatically. The three important functions of steam trap are:

1. Discharge condensate as soon as it is formed (unless it is desirable to use the sensible heat of the liquid condensate)
2. Have a negligible steam consumption (i.e. being energy efficient)
3. Have the capability of discharging air and other non-condensable gases.

Blow Down Valve

Boiler blowdown is water intentionally wasted from a boiler to avoid concentration of impurities during continuing evaporation of steam. The water is blown out of the boiler with some force by steam pressure within the boiler.

SAFETY VALVE PROPORTIONAL TYPE

CAST IRON / CARBON STEEL / STAINLESS STEEL



FIG 2501

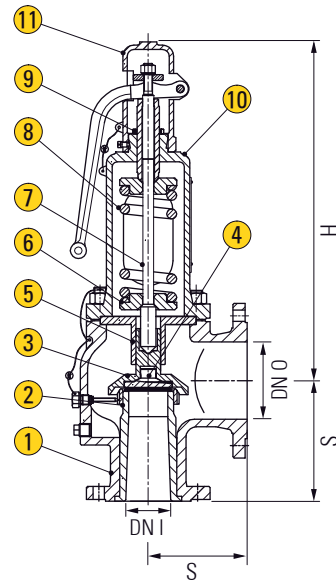
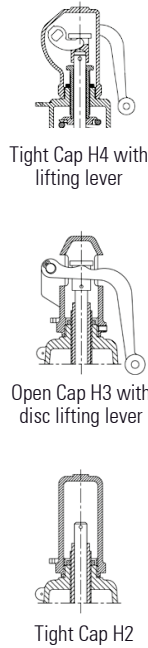

APPLICATION

Suitable for water, steam, oil, gases and others non-abrasive media (Refer to corrosion resistance table for valve materials selection).

SPECIFICATION

End Connection: Flange end to ANSI 150, ANSI 300, DIN PN16, PN40, JIS 10K, JIS 20K
Pressure Rating: DIN PN16, DIN PN40, Class 150 and Class 300
Type-test Approved Acc. to: DIN EN ISO 4126, AD2000-A2, TRD 421, ASME I, ASME IIIV and API 526

MATERIAL

Parts	Cast Iron Body	Carbon Steel Body	Stainless Steel Body
1 Valve Body	Cast Iron G250	Carbon Steel ASTM A216 WCB - EN 1.0619	Stainless Steel ASTM A351 CF8M - EN 1.4408
2 Seat	Stainless Steel ASTM 316 - EN 1.4401	Stainless Steel ASTM 316 - EN 1.4401	Stainless Steel ASTM 316 - EN 1.4401
3 Disc	Stainless Steel ASTM 420 - EN 1.4028	Stainless Steel ASTM 420 - EN 1.4028	Stainless Steel ASTM 316 - EN 1.4401
4 Ball	Stainless Steel ASTM 420 - EN 1.4028	Stainless Steel ASTM 420 - EN 1.4028	Stainless Steel ASTM 316 - EN 1.4401
5 Complete Guide	Cast Iron GS450/10 with Bush ASTM 430F Tenifer	Cast Iron GS450/10 with Bush ASTM 430F Tenifer or Stainless Steel ASTM 316 - EN 1.4401	Stainless Steel ASTM 316 - EN 1.4401
6 Spring Plate	AVP Steel	AVP Steel	Stainless Steel ASTM 316 - EN 1.4401
7 Spindle	Stainless Steel ASTM 430F - EN 1.4104	Stainless Steel ASTM 430F - EN 1.4104	Stainless Steel ASTM 316 - EN 1.4401
8 Spring	Carbon Steel Alloy Steel	Carbon Steel Alloy Steel	Stainless Steel ASTM 316 S42
9 Pressure Adjusting Screw	Brass OT58 / AVP Steel	Brass OT58 / AVP Steel	Stainless Steel ASTM 316 - EN 1.4401 with Bush in PTFE
10 Bonnet	Cast Iron GS450/10	Cast Iron GS450/10 or Carbon Steel ASTM A216 WCB - EN 1.0619	Stainless Steel ASTM A351 CF8M - EN 1.4408
11 Tight Cap H4 with Lifting Lever	Cast Iron GS450/10	Cast Iron GS450/10	Stainless Steel ASTM A351 CF8M - EN 1.4408

DIMENSIONS

Unit : mm

Size	EN Flange PN16 / PN25 / PN40	ANSI / ASME Flange CL150 / CL150	H	Actual Orifice Diameter	Actual Discharge Area	Disc Lift	Max Set Pressure Valve Body	
							Cast Iron	Cast Steel
DN I DN O	S	S		mm	cm ²	mm	barg	
15	90	85.1	223	12.5	1.23	2.3	16	40
20 x 20	95	89.7	223	18	2.54	3.1	16	40
20 x 25	100	96.3	223	18	2.54	3.1	16	40
25	100	96.3	223	18	2.54	3.1	16	40
32	105	102.9	223	18	2.54	3.1	16	40
40	115	114.5	223	23	4.15	3.5	16	40
50	125	124	273	29	6.61	3.8	16	40
65	145	145.2	330	37	10.75	4.0	16	37
80	155	154.8	375	46	16.62	5.1	16	35
100	175	174.8	435	60	28.27	7.1	16	30
125	200	197.8	545	74	43.00	8.5	16	25
150	225	222.4	645	92	66.48	11.4	16	16

*Specification given are subject to changed without further notice.

FLOW RATE TABLE

Unit : Kg/h

Set Pressure P	DN 15 - do 12.5			DN 20 - do 18			DN 25 - do 18			DN 32 - do 18			DN 40 - do 23			DN 50 - do 29		
	Water	Air	Sat. Steam	Water	Air	Sat. Steam	Water	Air	Sat. Steam	Water	Air	Sat. Steam	Water	Air	Sat. Steam	Water	Air	Sat. Steam
	a 25°C	a 25°C		a 25°C	a 25°C		a 25°C	a 25°C		a 25°C	a 25°C		a 25°C	a 25°C		a 25°C	a 25°C	
Bar	Kg/h	Kg/h	Kg/h	Kg/h	Kg/h	Kg/h	Kg/h	Kg/h	Kg/h	Kg/h	Kg/h	Kg/h	Kg/h	Kg/h	Kg/h	Kg/h	Kg/h	Kg/h
0.25	1.171	40	26	2.434	87	53	2.434	87	53	2.434	87	53	3.994	136	87	6.350	216	145
0.5	1.536	53	33	3.203	116	70	3.203	116	70	3.203	116	70	5.230	182	114	8.315	289	190
0.75	1.830	65	41	3.813	142	85	3.813	142	85	3.813	142	85	6.226	221	139	9.898	352	235
1	2.084	76	48	4.338	158	101	4.338	158	101	4.338	158	101	7.083	258	165	11.260	411	263
1.5	2.562	99	62	5.313	205	129	5.313	205	129	5.313	205	129	8.675	335	211	13.792	533	336
2	2.958	119	75	6.135	248	156	6.135	248	156	6.135	248	156	10.017	405	256	15.926	644	407
2.5	3.308	144	90	6.860	298	188	6.860	298	188	6.860	298	188	11.200	488	306	17.806	775	488
3	3.624	165	103	7.514	342	215	7.514	342	215	7.514	342	215	12.269	559	351	19.506	889	558
4	4.184	207	129	8.677	430	268	8.677	430	268	8.677	430	268	14.167	702	438	22.524	1.117	697
5	4.678	249	155	9.701	518	321	9.701	518	321	9.701	518	321	15.840	846	525	25.182	1.345	835
6	5.125	292	180	10.627	606	374	10.627	606	374	10.627	606	374	17.352	989	611	27.586	1.573	972
7	5.536	334	206	11.479	694	427	11.479	694	427	11.479	694	427	18.742	1.133	698	29.797	1.802	1.109
8	5.918	377	231	12.272	782	480	12.272	782	480	12.272	782	480	20.037	1.277	784	31.854	2.030	1.246
9	6.277	419	256	13.016	870	532	13.016	870	532	13.016	870	532	21.252	1.421	869	33.787	2.259	1.383
10	6.616	462	282	13.720	959	585	13.720	959	585	13.720	959	585	22.402	1.565	955	35.615	2.489	1.519
12	7.248	547	332	15.030	1.136	689	15.030	1.136	689	15.030	1.136	689	24.540	1.854	1.125	39.015	2.949	1.789
14	7.829	633	382	16.235	1.313	793	16.235	1.313	793	16.235	1.313	793	26.507	2.144	1.296	42.141	3.409	2.060
16	8.370	719	433	17.356	1.491	898	17.356	1.491	898	17.356	1.491	898	28.337	2.435	1.466	45.051	3.871	2.331
18	8.877	805	483	18.409	1.670	1.002	18.409	1.670	1.002	18.409	1.670	1.002	30.057	2.726	1.602	47.784	4.334	2.602
20	9.358	891	533	19.405	1.848	1.106	19.405	1.848	1.106	19.405	1.848	1.106	31.683	3.018	1.806	50.370	4.799	2.872
22	9.815	978	583	20.352	2.028	1.209	20.352	2.028	1.209	20.352	2.028	1.209	33.230	3.311	1.975	52.829	5.264	3.140
24	10.251	1.064	633	21.257	2.207	1.314	21.257	2.207	1.314	21.257	2.207	1.314	34.708	3.604	2.145	55.178	5.731	3.411
26	10.670	1.151	684	22.126	2.388	1.419	22.126	2.388	1.419	22.126	2.388	1.419	36.125	3.899	2.316	57.432	6.198	3.683
28	11.073	1.238	735	22.961	2.568	1.524	22.961	2.568	1.524	22.961	2.568	1.524	37.489	4.194	2.488	59.601	6.667	3.956
30	11.462	1.326	785	23.767	2.749	1.628	23.767	2.749	1.628	23.767	2.749	1.628	38.806	4.489	2.658	61.693	7.137	4.227
32	11.838	1.413	835	24.547	2.931	1.733	24.547	2.931	1.733	24.547	2.931	1.733	40.079	4.785	2.829	63.717	7.608	4.498
34	12.202	1.501	886	25.303	3.113	1.837	25.303	3.113	1.837	25.303	3.113	1.837	41.312	5.082	3.000	65.679	8.080	4.769
36	12.556	1.589	936	26.037	3.295	1.941	26.037	3.295	1.941	26.037	3.295	1.941	42.511	5.380	3.170	67.583	8.553	5.039
38	12.900	1.677	987	26.750	3.478	2.046	26.750	3.478	2.046	26.750	3.478	2.046	43.676	5.678	3.342	69.436	9.028	5.313
40	13.235	1.765	1.038	27.445	3.661	2.152	27.445	3.661	2.152	27.445	3.661	2.152	44.811	5.977	3.514	71.240	9.503	5.587

FLOW RATE TABLE

Unit : Kg/h

Set Pressure P	DN 65 - do 37			DN 80 - do 46			DN 100 - do 60			DN 125 - do 74			DN 150 - do 92		
	Water	Air	Sat. Steam	Water	Air	Sat. Steam	Water	Air	Sat. Steam	Water	Air	Sat. Steam	Water	Air	Sat. Steam
	a 25°C	a 25°C		a 25°C	a 25°C		a 25°C	a 25°C		a 25°C	a 25°C		a 25°C	a 25°C	
Bar	Kg/h	Kg/h	Kg/h	Kg/h	Kg/h	Kg/h	Kg/h	Kg/h	Kg/h	Kg/h	Kg/h	Kg/h	Kg/h	Kg/h	Kg/h
0.25	10.337	352	227	15.978	570	351	27.183	926	597	41.349	1408	909	63.912	2177	1405
0.5	13.536	471	296	20.923	762	457	35.597	1240	778	54.147	1964	1184	83.693	2915	1831
0.75	16.113	573	362	24.905	927	559	42.371	1508	952	64.452	2294	1448	99.621	3546	2239
1	18.330	670	429	28.333	1035	663	48.203	1762	1128	73.323	2861	1716	113.332	4143	2652
1.5	22.451	869	547	34.702	1343	845	59.039	2285	1439	89.805	3476	2189	138.808	5373	3383
2	25.925	1048	663	40.071	1621	1025	68.174	2758	1744	103.701	4195	2653	160.285	6845	4101
2.5	28.985	1262	794	44.801	1952	1227	76.222	3321	2089	115.942	5051	3177	179.207	7808	4911
3	31.752	1.448	908	49.078	2.238	1.404	83.498	3.808	2.389	127.010	5.793	3.634	196.313	8.954	5.618
4	36.665	1.818	1.134	56.671	2.811	1.753	96.416	4.783	2.983	146.660	7.275	4.538	226.687	11.245	7.015
5	40.993	2.189	1.359	63.361	3.384	2.101	107.798	5.758	3.575	163.973	8.759	5.438	253.447	13.539	8.405
6	44.906	2.561	1.583	69.409	3.959	2.447	118.088	6.735	4.163	179.625	10.245	6.333	277.638	15.836	9.788
7	48.504	2.933	1.806	74.971	4.534	2.792	127.550	7.714	4.750	194.019	11.733	7.225	299.886	18.136	11.168
8	51.854	3.305	2.029	80.148	5.109	3.136	136.358	8.693	5.335	207.416	13.223	8.116	320.594	20.439	12.545
9	54.999	3.678	2.251	85.010	5.686	3.479	144.631	9.674	5.920	219.999	14.715	9.005	340.043	22.745	13.919
10	57.975	4.052	2.473	89.609	6.263	3.822	152.455	10.656	6.503	231.901	16.209	9.892	358.439	25.053	15.290
12	63.509	4.800	2.913	98.163	7.419	4.503	167.008	12.623	7.662	254.038	19.202	11.655	392.655	29.679	18.014
14	68.598	5.550	3.354	106.030	8.579	5.184	180.391	14.596	8.820	274.395	22.202	13.416	424.120	34.317	20.737
16	73.336	6.302	3.794	113.352	9.741	5.864	192.848	16.573	9.978	293.344	25.210	15.177	453.408	38.966	23.459
18	77.785	7.056	4.235	120.229	10.906	6.547	204.548	18.556	11.138	311.141	28.226	16.943	480.917	43.627	26.188
20	81.993	7.812	4.676	126.734	12.075	7.227	215.615	20.543	12.296	327.975	31.249	18.704	506.936	48.300	28.911
22	85.996	8.569	5.112	132.921	13.246	7.901	226.141	22.535	13.443	343.986	34.279	20.449	531.684	52.984	31.607
24	89.821	9.329	5.553	138.832	14.419	8.583	236.199	24.532	14.603	359.285	37.317	22.213	555.331	57.679	34.334
26	93.490	10.090	5.995	144.503	15.596	9.267	245.846	26.534	15.767	373.960	40.362	23.983	578.012	62.386	37.070
28	97.020	10.853	6.439	149.959	16.776	9.953	255.129	28.541	16.934	388.080	43.415	25.759	599.837	67.104	39.814
30	100.426	11.618	6.880	155.224	17.958	10.635	264.086	30.553	18.094	401.705	46.474	27.523	620.897	71.834	42.542
32	103.720	12.385	7.322	160.316	19.143	11.318	272.750	32.569	19.256	414.883	49.541	29.290	641.265	76.574	45.273
34	106.913	13.154	7.764	165.251	20.331	12.000	281.146	34.590	20.417	427.655	52.616	31.057	661.007	81.326	48.003
36	110.014	13.924	8.203	170.044	21.522	12.680	289.300	36.616	21.573	440.058	55.697	32.815	680.177	86.089	50.721
38	113.030	14.696	8.648	174.705	22.715	13.368	297.230	38.646	22.743	452.121	58.785	34.595	698.822	90.862	53.472
40	115.967	15.470	9.095	179.245	23.911	14.058	304.955	40.681	23.917	463.870	61.881	36.381	716.983	95.647	56.232

Note 1) Flow rates have been calculated according to EN 4126-1 rules with overpressure 10% (0,1 bar if p<1 barg)

Note 2) Approximate intermediate values can be obtained by linear interpolation

Note 3) Flow rates given in this table are undemanding; Valves Malaysia (M) Sdn Bhd will always check fluid mechanical sizing of each safety valve, and indicate calculated flow rate in every relevant document (Specification sheet in case of offer, inspection certificate in case of order, calculation sheet when applicable)

Diagram showing coefficient of discharge Kd trend vs. pb/po ratio (gaseous)

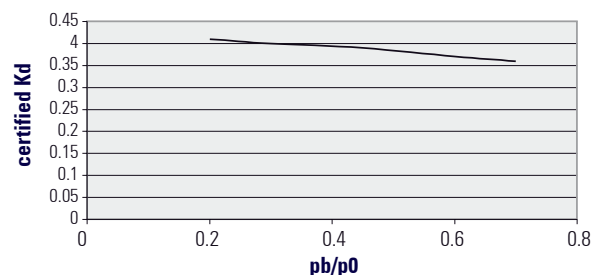

SAFETY VALVE FULL LIFT TYPE

CAST IRON / CARBON STEEL / STAINLESS STEEL



FIG 630-*1-*2-*3

Note : *1 Class | *2 Material | *3 Connection

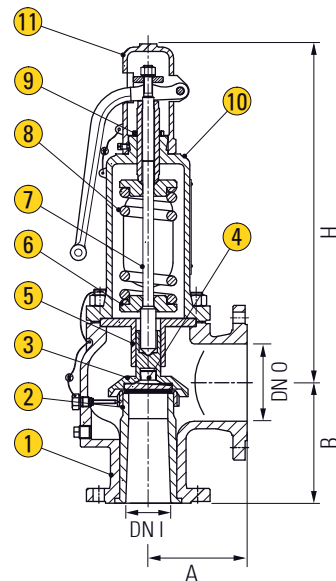
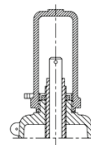

APPLICATION

Suitable for water, steam, oil, gases and others non-abrasive media (Refer to corrosion resistance table for valve materials selection).

SPECIFICATION

End Connection

Flange end to ANSI 150, ANSI 300, DIN PN16, PN40, JIS 10K, JIS 20K
DIN PN16, DIN PN40, Class 150 and 300
DIN EN ISO 4126, AD2000-A2, TRD 421, ASME I, ASME IIIV and API 526

Pressure Rating

Type-test Approved Acc. to

MATERIAL

Parts	Cast Iron Body	Carbon Steel Body	Stainless Steel Body
1 Valve Body	Cast Iron G250	Carbon Steel ASTM A216 WCB - EN 1.0619	Stainless Steel ASTM A351 CF8M - EN 1.4408
2 Full Nozzle (Seat)	Stainless Steel ASTM 316 - EN 1.4401	Stainless Steel ASTM 316 - EN 1.4401	Stainless Steel ASTM 316 - EN 1.4401
3 Disc	Stainless Steel ASTM 420 - EN 1.4028	Stainless Steel ASTM 420 - EN 1.4028	Stainless Steel ASTM 316 - EN 1.4401
4 Ball	Stainless Steel ASTM 420 - EN 1.4028	Stainless Steel ASTM 420 - EN 1.4028	Stainless Steel ASTM 316 - EN 1.4401
5 Complete Guide	Cast Iron GS450/10 with Bush ASTM 430F Tenifer	Cast Iron GS450/10 with Bush ASTM 430F Tenifer or Stainless Steel ASTM 316 - EN 1.4401	Stainless Steel ASTM 316 - EN 1.4401
6 Spring Plate	AVP Steel	AVP Steel	Stainless Steel ASTM 316 - EN 1.4401
7 Spindle	Stainless Steel ASTM 430F - EN 1.4104	Stainless Steel ASTM 430F - EN 1.4104	Stainless Steel ASTM 316 - EN 1.4401
8 Spring	Carbon Steel Alloy Steel	Carbon Steel Alloy Steel	Stainless Steel ASTM 316 S42
9 Pressure Adjusting Screw	Brass OT58 / AVP Steel	Brass OT58 / AVP Steel	Stainless Steel ASTM 316 - EN 1.4401 with Bush in PTFE
10 Bonnet	Cast Iron GS450/10	Cast Iron GS450/10 or Carbon Steel ASTM A216 WCB - EN 1.0619	Stainless Steel ASTM A351 CF8M - EN 1.4408
11 Tight Cap H4 with Lifting Lever	Cast Iron GS450/10	Cast Iron GS450/10	Stainless Steel ASTM A351 CF8M - EN 1.4408

DIMENSIONS

Unit : mm

Size	EN Flange PN16 / PN25 / PN40		ANSI / ASME Flange CL150 / CL150 CL300 / CL150		H	Actual Orifice Diameter	Actual Discharge Area	Size	Disc Lift	Max Set Pressure
	A	B	A	B						
DN I	A	B	A	B		mm	cm ²	DN O	mm	barg
20	95	85	94.5	82.9	215	18	2.54	40	5.5	40
25	100	105	99.5	104.5	265	23	4.15	40	6.9	40
32	110	115	109	116	330	29	6.61	50	7.5	40
40	115	140	117.2	142.6	375	37	10.75	65	10.2	40
50	120	150	121.3	151.2	420	46	16.62	80	13.5	40
65	136	172	139.8	175.4	525	60	28.27	100	17.0	40
80	173	197	157.8	201.6	600	74	43.00	125	21.5	40
100	188	220	179.4	227.7	655	92	66.48	150	27.6	40
125	198	246	202.6	254.9	665	98	75.43	200	29.4	30
150	216	288	223.2	296.5	780	125	122.72	250	37.5	30
200	345	350	349.9	357.3	1161	165	213.82	350	48	30
250	454	450	459.5	459.6	1161	200	314.16	400	58	20

*Specification given are subject to changed without further notice.

FLOW RATE TABLE

Unit : Kg/h

Set Pressure P	DN 20 - do 18mm			DN 25 - do 23mm			DN 32 - do 29mm			DN 40 - do 37mm			DN 50 - do 46mm			DN 65 - do 60mm		
	Water	Air	Sat. Steam	Water	Air	Sat. Steam	Water	Air	Sat. Steam	Water	Air	Sat. Steam	Water	Air	Sat. Steam	Water	Air	Sat. Steam
	a 25°C	a 25°C		a 25°C	a 25°C		a 25°C	a 25°C		a 25°C	a 25°C		a 25°C	a 25°C		a 25°C	a 25°C	
Bar	Kg/h	Kg/h	Kg/h	Kg/h	Kg/h	Kg/h	Kg/h	Kg/h	Kg/h	Kg/h	Kg/h	Kg/h	Kg/h	Kg/h	Kg/h	Kg/h	Kg/h	Kg/h
0.25	3.822	145	94	6.241	242	156	9.922	371	239	16.152	583	376	24.965	884	570	42.474	1.447	933
0.5	5.005	196	123	8.173	331	208	12.993	509	319	21.151	814	511	32.692	1.236	776	55.620	2.029	1.274
0.75	5.958	243	153	9.728	410	259	15.466	632	399	25.176	1.012	639	38.914	1.564	988	66.206	2.573	1.624
1	6.778	290	185	11.067	488	312	17.595	752	481	28.641	1.206	772	44.270	1.835	1.174	75.318	3.122	1.998
1.5	8.302	382	241	13.555	643	405	21.550	993	625	35.080	1.641	1.033	54.222	2.500	1.574	92.249	4.190	2.638
2	9.587	475	300	15.652	788	498	24.884	1.235	781	40.508	2.039	1.252	62.611	3.107	1.965	106.522	5.286	3.343
2.5	10.718	565	355	17.500	936	589	27.822	1.488	936	45.290	2.423	1.524	70.002	3.745	2.356	119.097	6.283	3.952
3	11.741	657	412	19.171	1.088	683	30.478	1.730	1.086	49.613	2.817	1.768	76.685	4.355	2.733	130.466	7.409	4.650
4	13.558	837	522	22.137	1.367	865	35.193	2.173	1.356	57.289	3.587	2.238	88.549	5.544	3.460	150.651	9.433	5.886
5	15.159	1.022	634	24.750	1.668	1.036	39.348	2.653	1.647	64.052	4.318	2.682	99.002	6.675	4.146	168.435	11.357	7.053
6	16.606	1.195	739	27.113	1.951	1.207	43.104	3.103	1.918	70.166	5.051	3.123	108.452	7.807	4.828	184.513	13.282	8.214
7	17.936	1.368	843	29.285	2.235	1.377	46.558	3.553	2.189	75.788	5.784	3.564	117.143	8.940	5.508	199.298	15.210	9.372
8	19.175	1.542	947	31.308	2.518	1.546	49.773	4.004	2.459	81.022	6.518	4.003	125.232	10.075	6.187	213.060	17.140	10.527
9	20.338	1.716	1.051	33.207	2.802	1.716	52.792	4.455	2.728	85.937	7.253	4.441	132.829	11.210	6.865	225.986	19.073	11.680
10	21.439	1.890	1.154	35.003	3.086	1.885	55.648	4.907	2.997	90.586	7.988	4.879	140.015	12.347	7.542	238.211	21.007	12.831
12	23.485	2.239	1.360	38.345	3.656	2.221	60.960	5.812	3.531	99.233	9.462	5.748	153.380	14.625	8.885	260.950	24.882	15.117
14	25.367	2.589	1.566	41.418	4.227	2.557	65.846	6.720	4.065	107.185	10.939	6.617	165.672	16.908	10.228	281.861	28.767	17.402
16	27.119	2.939	1.771	44.278	4.799	2.892	70.393	7.629	4.599	114.587	12.419	7.486	177.112	19.196	11.571	301.326	32.659	19.686
18	28.764	3.290	1.977	46.964	5.372	3.229	74.663	8.541	5.133	121.539	13.903	8.357	187.858	21.489	12.917	319.607	36.561	21.976
20	30.320	3.642	2.183	49.505	5.947	3.565	78.703	9.454	5.667	128.115	15.390	9.226	198.021	23.788	14.260	336.899	40.471	24.261
22	31.801	3.995	2.387	51.922	6.522	3.897	82.545	10.369	6.196	134.369	16.880	10.086	207.689	26.091	15.590	353.346	44.389	26.523
24	33.215	4.348	2.593	54.231	7.099	4.233	86.216	11.287	6.730	140.346	18.373	10.956	216.926	28.399	16.935	369.061	48.317	28.812
26	34.572	4.702	2.799	56.446	7.678	4.571	89.738	12.206	7.267	146.078	19.870	11.829	225.786	30.713	18.284	384.135	52.252	31.108
28	35.877	5.057	3.006	58.577	8.257	4.909	93.126	13.128	7.805	151.593	21.370	12.705	234.311	33.031	19.638	398.639	56.197	33.411
30	37.137	5.413	3.213	60.634	8.838	5.245	96.396	14.051	8.339	156.916	22.873	13.575	242.537	35.354	20.983	412.635	60.149	35.700
32	38.355	5.769	3.419	62.623	9.420	5.582	99.558	14.976	8.875	162.063	24.379	14.447	250.494	37.682	22.330	426.171	64.110	37.991
34	39.536	6.127	3.625	64.551	10.003	5.919	102.623	15.904	9.410	167.053	25.889	15.318	258.206	40.015	23.677	439.292	68.080	40.283
36	40.682	6.485	3.830	66.423	10.588	6.254	105.599	16.833	9.943	171.897	27.401	16.185	265.694	42.353	25.017	452.032	72.057	42.563
38	41.798	6.843	4.038	68.244	11.174	6.593	108.494	17.764	10.482	176.609	28.917	17.063	272.977	44.696	26.374	464.423	76.043	44.872
40	42.884	7.203	4.246	70.017	11.761	6.934	111.313	18.697	11.023	181.199	30.436	17.944	280.071	47.044	27.736	476.492	80.037	47.188

FLOW RATE TABLE

Unit : Kg/h

Set Pressure P	DN 80 - do 74mm			DN 100 - do 92mm			DN 125 - do 98mm			DN 150 - do 125mm			DN 200 - do 165mm			DN 250 - do 200mm		
	Water	Air	Sat. Steam	Water	Air	Sat. Steam	Water	Air	Sat. Steam	Water	Air	Sat. Steam	Water	Air	Sat. Steam	Water	Air	Sat. Steam
	a 25°C	a 25°C		a 25°C	a 25°C		a 25°C	a 25°C		a 25°C	a 25°C		a 25°C	a 25°C		a 25°C	a 25°C	
Bar	Kg/h	Kg/h	Kg/h	Kg/h	Kg/h	Kg/h	Kg/h	Kg/h	Kg/h	Kg/h	Kg/h	Kg/h	Kg/h	Kg/h	Kg/h	Kg/h	Kg/h	Kg/h
0.25	64.608	2.289	1.477	99.862	3.810	2.458	113.313	4.246	2.740	184.352	6.909	4.458	321.215	12.257	7.909	471.941	17.688	11.413
0.5	84.605	3.201	2.010	130.770	5.124	3.218	148.384	5.814	3.651	241.410	9.460	5.941	420.632	16.483	10.351	618.009	24.217	15.209
0.75	100.706	4.049	2.556	155.658	6.468	4.083	176.623	7.339	4.633	287.353	11.747	7.417	500.684	20.804	13.136	735.624	30.074	18.988
1	114.567	4.825	3.089	177.081	7.695	4.926	200.932	8.732	5.590	326.902	13.988	8.954	569.594	24.373	15.602	836.870	35.810	22.924
1.5	140.321	6.566	4.135	216.888	10.149	6.391	246.100	11.516	7.252	400.388	18.736	11.799	697.636	32.647	20.558	1,024.993	47.966	30.205
2	162.032	8.274	5.233	250.446	12.609	7.974	284.178	14.308	9.048	462.338	23.278	14.721	805.577	40.560	25.650	1,183.585	59.592	37.686
2.5	181.160	9.830	6.183	280.011	15.194	9.557	317.726	17.001	10.694	516.916	27.660	17.399	900.675	48.195	30.316	1,323.307	70.810	44.541
3	198.453	11.427	7.171	306.740	17.420	10.932	348.054	19.766	12.405	566.259	32.158	20.182	986.650	56.033	35.165	1,449.624	82.326	51.666
4	229.157	14.349	8.954	354.198	22.179	13.840	401.904	25.166	15.705	653.869	40.944	25.550	1,139.302	70.364	44.519	1,673.905	103.382	64.514
5	256.208	17.275	10.729	396.009	26.702	16.584	449.347	30.298	18.817	731.055	49.293	30.615	1,273.791	85.888	53.344	1,871.502	126.190	78.375
6	280.664	20.204	12.494	433.810	31.229	19.312	492.239	35.435	21.914	800.838	57.651	35.652	1,395.380	100.451	62.121	2,050.145	147.587	91.270
7	303.154	23.137	14.256	468.572	35.762	22.035	531.683	40.578	25.003	865.010	66.019	40.679	1,507.194	115.031	70.879	2,214.426	169.008	104.139
8	324.088	26.073	16.013	500.928	40.300	24.751	568.397	45.727	28.085	924.741	74.396	45.693	1,611.268	129.627	79.615	2,367.337	190.453	116.974
9	343.749	29.012	17.767	531.318	44.842	27.462	602.880	50.882	31.161	980.842	82.782	50.696	1,709.019	144.240	88.334	2,510.955	211.923	129.783
10	362.346	31.954	19.518	560.061	49.391	30.168	635.495	56.043	34.231	1,033.904	91.178	55.692	1,801.474	158.869	97.039	2,646.795	233.416	142.573
12	396.934	37.849	22.995	613.523	58.502	35.542	696.158	66.382	40.329	1,132.598	107.998	65.613	1,973.438	188.177	114.325	2,899.450	276.476	167.970
14	428.743	43.757	26.471	662.688	67.634	40.915	751.944	76.743	46.426	1,223.358	124.856	75.532	2,131.579	217.550	131.606	3,131.797	319.633	193.361
16	458.350	49.679	29.945	708.450	76.786	46.285	803.870	87.128	52.519	1,307.838	141.752	85.445	2,278.777	246.989	148.880	3,348.066	362.886	218.741
1																		

SAFETY VALVE API 526

CARBON STEEL / ALLOY STEEL / STAINLESS STEEL



FIG 630-*1-*2-*3

Note : *1 Class | *2 Material | *3 Connection

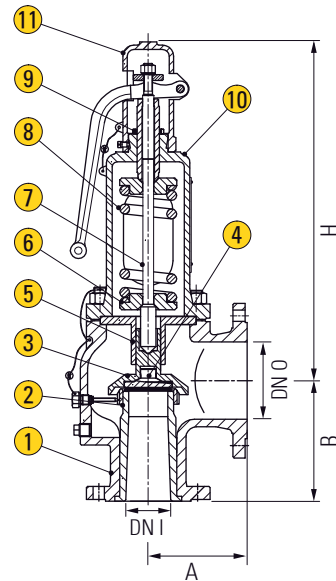
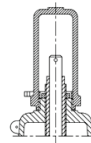
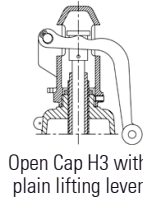

APPLICATION

Suitable for water, steam, oil, gases and others non-abrasive media (Refer to corrosion resistance table for valve materials selection).

SPECIFICATION

Pressure Rating Class 150 and 300
Flanged End Dimension ASME B16.5
Type-test Approved Acc. to ASME I, ASME IIIV and API 526

MATERIAL

Parts	Carbon Steel Body	Alloy Steel Body	Stainless Steel Body
1 Valve Body	Carbon Steel ASTM A216 WCB - EN 1.0619	Alloy Steel ASTM A271 WC6 - EN 1.7357	Stainless Steel ASTM A351 CF8M - EN 1.4408
2 Full Nozzle (Seat)	Stainless Steel ASTM 316 - EN 1.4401	Stainless Steel ASTM 316 - EN 1.4401	Stainless Steel ASTM 316 - EN 1.4401
3 Disc	Stainless Steel ASTM 420 - EN 1.4028 or ASTM 316 - EN 1.4401	Stainless Steel ASTM 420 - EN 1.4028 or ASTM 316 - EN 1.4401	Stainless Steel ASTM 316 - EN 1.4401
4 Ball	Stainless Steel ASTM 420 - EN 1.4028 or ASTM 316 - EN 1.4401	Stainless Steel ASTM 420 - EN 1.4028 or ASTM 316 - EN 1.4401	Stainless Steel ASTM 316 - EN 1.4401
5 Guide	Carbon Steel or Stainless Steel ASTM 316 - EN 1.4401	Carbon Steel or Stainless Steel ASTM 316 - EN 1.4401	Stainless Steel ASTM 316 - EN 1.4401
6 Spring Plate	AVP Steel or Stainless Steel or ASTM 316 - EN 1.4401	AVP Steel or Stainless Steel or ASTM 316 - EN 1.4401	Stainless Steel ASTM 316 - EN 1.4401
7 Spindle	Stainless Steel ASTM 430F - EN 1.4104 or ASTM 316 - EN 1.4401	Stainless Steel ASTM 430F - EN 1.4104 or ASTM 316 - EN 1.4401	Stainless Steel ASTM 316 - EN 1.4401
8 Spring	Carbon Steel Alloy Steel	Carbon Steel Alloy Steel	Stainless Steel ASTM 316 S42
9 Pressure Adjusting Screw	AVP Steel or Stainless Steel ASTM 316 - EN 1.4401 with bush PTFE	AVP Steel or Stainless Steel ASTM 316 - EN 1.4401 with bush PTFE	Stainless Steel ASTM 316 - EN 1.4401 with Bush in PTFE
10 Bonnet	Carbon Steel ASTM A216 WCB - EN 1.0619	Carbon Steel ASTM A216 WCB - EN 1.0619	Stainless Steel ASTM A351 CF8M - EN 1.4408
11 Tight Cap H4 with Lifting Lever	ASTM A216 WCB - EN 1.0619	ASTM A216 WCB - EN 1.0619	Stainless Steel ASTM A351 CF8M - EN 1.4408

DIMENSIONS - INLET x OUTLET FLANGE RATINGS

Unit : mm

DN I (inch)	1x2	1-1/2x2	1-1/2x3		2x3		3x4		3x6		4x6			6x8		6x10	8x10				
Orifice	D/E	F		G	H	H	J	J	K	L	K	L	M	N	P	Q	R	R	T		
ASME CL 150 x 150	A	114.3	120.7	120.7	120.7	123.8	-	123.8	-	161.9	161.9	-	-	184.2	209.6	228.6	228.6	241.3	241.3	-	279.4
	B	104.8	123.8	123.8	123.8	130.2	-	136.5	-	155.6	155.6	-	-	117.8	196.9	181	181	239.7	239.7	-	276.2
ASME CL 300 x 150	A	114.3	120.7	120.7	120.7	152.4	123.8	123.8	180.9	161.9	161.9	-	181	184.2	209.6	228.6	254	241.3	241.3	266.7	279.4
	B	104.8	123.8	123.8	123.8	130.2	130.2	136.5	184.1	155.6	155.6	-	179.4	177.8	196.9	181	181	239.7	239.7	239.7	276.2
ASME CL 600 x 150	A	114.3	152.4	152.4	152.4	152.4	-	161.9	-	180.9	180.9	-	181	203.2	222.3	254	254	241.3	-	266.7	-
	B	104.8	123.8	123.8	123.8	-	153.9	-	184.1	184.1	-	-	179.4	177.8	196.9	225.4	225.4	239.7	-	239.7	-
ASME CL 900 x 150	A	-	-	-	-	-	-	161.9	-	180.9	-	-	215.9	222.3	222.3	222.3	254	254	-	-	-
	B	-	-	-	-	-	-	153.9	-	184.1	-	-	198.4	196.9	196.9	196.9	225.4	225.4	-	-	-
H		320	373		386		425		580		645		684			766		766	1280		

*Specification given are subject to changed without further notice.

FLOW RATE TABLE

Unit : Kg/h

Set Pressure P	Orifice D			Orifice E			Orifice F			Orifice G			Orifice H			Orifice J			Orifice K			
	Water	Air	Sat. Steam	Water	Air	Sat. Steam	Water	Air	Sat. Steam	Water	Air	Sat. Steam	Water	Air	Sat. Steam	Water	Air	Sat. Steam	Water	Air	Sat. Steam	
	a 25°C	a 25°C		a 25°C	a 25°C		a 25°C	a 25°C		a 25°C	a 25°C		a 25°C	a 25°C		a 25°C	a 25°C		a 25°C	a 25°C		
Bar	Kg/h	Kg/h	Kg/h	Kg/h	Kg/h	Kg/h	Kg/h	Kg/h	Kg/h	Kg/h	Kg/h	Kg/h	Kg/h	Kg/h	Kg/h	Kg/h	Kg/h	Kg/h	Kg/h	Kg/h	Kg/h	Kg/h
1	2465	107	69	4375	191	123	6875	300	193	11285	491	316	17570	766	494	28820	1257	810	41181	1796	1157	
2	3486	170	108	6187	303	192	9723	474	301	15959	778	494	24847	1213	771	40758	1989	1265	58239	2842	1808	
3	4270	250	158	7578	446	281	11908	699	440	19546	1145	722	30432	1787	1126	49918	2930	1846	71328	4186	2638	
4	4931	316	198	8750	563	352	13750	882	552	22570	1446	905	35140	2255	1411	57640	3697	2314	82363	5283	3307	
5	5513	381	237	9783	679	422	15373	1064	661	25234	1744	1083	39287	2720	1689	64443	4460	2770	92084	6372	3958	
6	6039	446	275	10717	794	489	16841	1244	767	27642	2039	1257	43037	3181	1961	70594	5215	3215	100873	7452	4593	
7	6523	511	313	11575	910	558	18190	1425	874	29857	2335	1433	46485	3642	2236	76251	5972	3666	108956	8533	5238	
8	6973	575	352	12375	1024	627	19446	1604	982	31919	2630	1610	49695	4102	2512	81515	6726	4119	116478	9611	5885	
9	7396	640	390	13125	1140	695	20625	1785	1089	33855	2926	1786	52709	4565	2785	86460	7484	4567	123544	10963	6525	
10	7796	705	429	13835	1255	764	21741	1965	1197	35686	3221	1963	55561	5025	3062	91137	8238	5020	130227	11771	7173	
12	8540	836	506	15156	1489	901	23816	2332	1411	39092	3823	2313	60863	5963	3608	99835	9776	5916	142656	13968	8453	
14	9224	966	583	16370	1721	1038	25724	2695	1626	42224	4417	2665	65740	6889	4157	107835	11295	6816	154006	16138	9739	
16	9861	1096	660	17500	1952	1176	27501	3057	1841	45140	5011	3081	70279	7816	4708	115280	12815	7719	164725	18311	11029	
18	10459	1226	737	18562	2184	1312	29169	3420	2055	47878	5606	3369	74542	8745	5255	122273	14337	8615	174718	20485	12310	
20	11025	1360	814	19566	2422	1450	30747	3793	2271	50468	6217	3722	78574	9697	5806	128887	15899	9519	184168	22717	13601	
22	11563	1491	889	20521	2655	1583	32247	4158	2479	52931	6815	4062	82410	10630	6338	135178	17428	10392	193158	24901	14848	
24	12078	1622	966	21433	2888	1720	33681	4523	2694	55285	7414	4416	86074	11563	6888	141189	18958	11293	201746	27088	16136	
26	12571	1757	1044	22309	3129	1859	35056	4900	2912	57542	8032	4773	98589	12528	7444	146954	20539	12205	209984	29347	17439	
28	13045	1888	1122	23151	3362	1998	36380	5264	3129	59714	8628	5128	109291	13458	7999	152501	22065	13114	217911	31527	18738	
30	13503	2024	1200	23963	3604	2137	37657	5645	3347	61810	9252	5485	96234	14431	8556	157854	23659	14027	225559	33804	20042	
35	14585	2354	1391	25883	4192	2477	40674	6564	3880	66763	10759	6359	103944	16781	9919	170501	27513	16262	243632	39311	23235	
40	15592	2691	1583	27670	4791	2820	43482	7503	4416	71372	12298	7237	111121	19182	11288	182274	31448	18508	260454	44934	26444	
45	16538	3028	1776	29349	5392	3162	46120	8444	4952	75702	13840	8116	117862	21587	12659	193330	35391	20755	276253	50567	29655	
50	17432	3367	1969	30937	5996	3507	48615	9390	5491	79797	15390	9001	124237	24005	14039	203788	39356	23017	291196	56232	32887	
55	18283	3708	2170	32446	6603	3865	50987	10341	6052	83691	16949	9919	130301	26436	15472	213735	43341	25366	305409	61926	36243	
60	19096	4060	2359	33889	7230	4201	53255	11322	6579	87413	18557	10783	136095	28945	16819	223239	47455	27575	318989	67803	39399	
70	20626	4750	2742	36605	8459	4883	57521	13246	7647	94417	21711	12533	146999	33863	19549	241125	55519	32050	344548	79325	45794	
80	22051	5447	3154	39132	9699	5616	61493	15188	8794	100936	24893	14414	157149	38827	22483	257774	63657	36861	368337	90953	52667	
90	23388	6156	3575	41506	10962	6366	65223	17166	9969	107058	28135	16339	166682	43884	25485	273410	71947	41782	390680	102798	59698	
100	24653	6862	3988	43751	12219	7101	68751	19134	11120	112849	31361	18226	175698	48915	28428	288200	80196	46608	411813	114584	66593	

FLOW RATE TABLE

Unit : Kg/h

Set Pressure P	Orifice L			Orifice M			Orifice N			Orifice P			Orifice Q			Orifice R			Orifice T			
	Water	Air	Sat. Steam	Water	Air	Sat. Steam	Water	Air	Sat. Steam	Water	Air	Sat. Steam	Water	Air	Sat. Steam	Water	Air	Sat. Steam	Water	Air	Sat. Steam	
	a 25°C	a 25°C		a 25°C	a 25°C		a 25°C	a 25°C		a 25°C	a 25°C		a 25°C	a 25°C		a 25°C	a 25°C		a 25°C	a 25°C		
Bar	Kg/h	Kg/h	Kg/h	Kg/h	Kg/h	Kg/h	Kg/h	Kg/h	Kg/h	Kg/h	Kg/h	Kg/h	Kg/h	Kg/h	Kg/h	Kg/h	Kg/h	Kg/h	Kg/h	Kg/h	Kg/h	Kg/h
1	63925	2788	1796	80661	3518	2267	97224	4241	2733	142919	6234	4017	247539	10798	6958	358444	15635	10075	582441	25408	16373	
2	90403	4411	2805	114072	5567	3540	137496	6712	4268	202118	9865	6274	350074	17087	10866	506917	24742	15735	823697	40206	25570	
3	110721	6497	4115	139709	8198	5167	168397	9917	6229	247544	14527	9156	428751	25162	15859	620884	36435	22963	1008818	59208	37317	
4	127850	8199	5132	161322	10346	6476	194448	12473	7807	285839	18334	11476	495079	31755	19877	716888	45980	28781	1164883	74720	46771	
5	142940	9889	6143	180364	12479	7751	217400	15045	9345	319577	22113	13736	553515	38302	23792	801506	55460	34450	1302379	90125	55983	
6	156583	11565	7129	197579	14594	8995	238149	17595	10845	350079	25861	15941	606345	44793	27610	878005	64859	39979	1426684	105400	64968	
7	169129	13243	8129	213410	16711	10258	257231	20147	12367	378129	29613	18177	654928	51291	31484	948354	74268	45588	1540995	120689	74084	
8	180807	14915	9133	228144	18821	11525	274991	22691	13895	404237	33352	20423	700147	57766	35373	1013833	83644	51219	1647393	135926	83234	
9	191774	16595	10127	241984	20941	12816	291672	25247	15452	428758	37109	22712	742618	64274	39338	1075333	93067	56793	1747324	151239	92292	
10	202148	18268	11132	255073	23052	14047	307449	27792	16935	451951	40849	24892	782788	70753	43114	1133500	102448	62428	1841842	166484	101449	
12	221442	21677	13119	279419	27354	16554	336794	32979	19958	495087	48473	29335	857502	83956	50809	1241687	121567	73571	2017638	197552	119556	
14	239185	25045	15115	301807	31604	19072	363779	38103	22995	534755	56004	33798	926207	97001	58539	1341175	140455	84764	2179296	228246	137745	
16	255699	28417	17116	322645	35858	21598	388896	43232	26039	571677	63543	38273	990157	110058	66291	1433777	159362	95987	2329766	258970	155984	
18	271210	31792	19104	342217	40117	24106	412487	48366	29064	606355	71089	42718	1050221	123129	73990	1520750	178288	107136	2471090	289726	174101	
20	285880	35255	21107	360728	44487	26634	434799	53635	32111	639155	78833	47198	1107030	136542	81749	1603011	197709	118370	2604757	321287	192357	
22	299834	38645	23043	378335	48764	29077	456021	58792	35057	670351	86413	51527	1161063	149671	89247	1681252	216720	129227	2731893	352180	210000	
24	313166	42038	25042	395158	53046	31599	476299	63954	38097	700159	94001	55996	1212690	162813	96988	1756011	235749	140436	2853369	383104	228215	
26	325954	45544	27064	411293	57470	34151	495747	69287	41174	728749	101840	60518	1262208	176390	104819	1827714	255408	151775	2969880	415050	246642	
28	338258	48927	29079	426819	61739	36694	514461	74435	44240	756258	109406	65024	1309855	189494	112625	1896709	274383	163077	3081991	445885	265009	
30	350131	52465	31104	441800	66199	39249	532518	79812	47320	782802												

SAFETY VALVE PROPOTIONAL TYPE

BRONZE

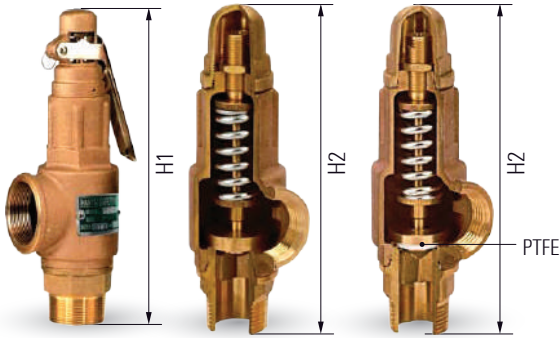

FVS-10L

FVS-10

FVS-10T

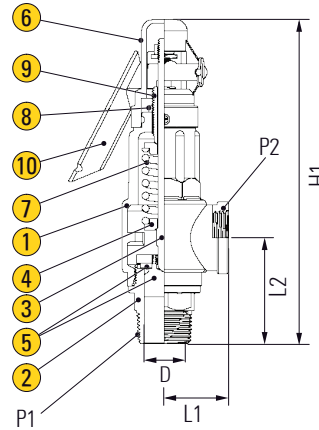

FVS-10LT

APPLICATION

Suitable for water, steam, oil, gases and non-abrasive media
(Refer to corrosion resistance table for valve materials selection).

SPECIFICATION

End Connection	Male thread inlet Female thread outlet
Adjustment Range	Standard 0.3 to 10 kg/cm ² Up to 40 Bar (optional)
Working Temperature	Up to 225°C
Optional	Lifting lever, Disc with PTFE

MATERIAL

Parts	Material			
	FVS-10L with lever	FVS-10 without lever	FVS-10LT with lever	FVS-10T without lever
1 Valve Body	Bronze	Bronze	Bronze	Bronze
2 Valve Seat	Brass	Brass	Brass	Brass
3 Spindle	Brass	Brass	Brass	Brass
4 Spring Seat	Brass	Brass	Brass	Brass
5 Disc	Brass	Brass	Brass + PTFE	Brass + PTFE
6 Cap	Bronze	Brass	Bronze	Brass
7 Spring	Steel	Steel	Steel	Steel
8 Nut	Brass	Brass	Brass	Brass
9 Adjusting Screw	Brass	Brass	Brass	Brass
10 Handle	Steel	-	Steel	-
Working Pressure	0.3 ~ 40 (kg/cm ²)			
Working Temperature	-45°C ~ 225°C			

DIMENSIONS

Unit : mm

Size P1 x P2	Orifice	Lift	L1	L2	H1	H2
3/4 x 3/4	19	0.76	36	55	169	145
1 x 1	25	1	40	65	199	175
1-1/4 x 1-1/4	32	1.28	52	75	223	198
1-1/2 x 1-1/2	38	1.52	58	86	243	225
2 x 2	50	2	65	100	248	256

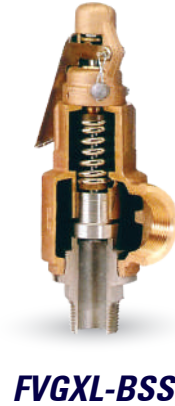
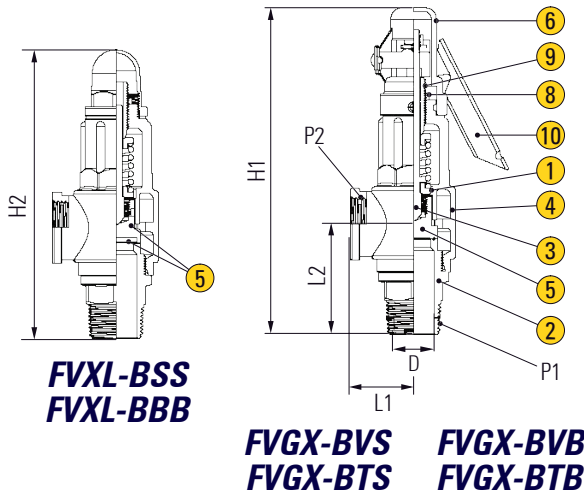

APPLICATION

Suitable for water, steam, oil, gases and non-abrasive media
 (Refer to corrosion resistance table for valve materials selection).

SPECIFICATION

End Connection	Male thread inlet Female thread outlet
Adjustment Range	Standard 0.3 to 10 kg/cm ² Up to 40 Bar (optional)
Working Temperature	Up to 225°C
Optional	Lifting lever, Disc with PTFE

MATERIAL

Parts	Material					
	FVXL-BSS with lever	FVX-BSS without lever	FVGXL-BVS with lever	FVGX-BVS without lever	FVGXL-BTS with lever	FVGX-BTS without lever
1 Valve Body	Bronze	Bronze	Bronze	Bronze	Bronze	Bronze
2 Valve Seat	SS304	SS304	SS304	SS304	SS304	SS304
3 Spindle	Brass	Brass	Brass	Brass	Brass	Brass
4 Spring Seat	Brass	Brass	Brass	Brass	Brass	Brass
5 Disc	SS304	SS304	SS304 + Viton	SS304 + Viton	SS304 + PTFE	SS304 + PTFE
6 Cap	Bronze	Brass	Bronze	Brass	Bronze	Brass
7 Spring	Steel	Steel	Steel	Steel	Steel	Steel
8 Nut	Brass	Brass	Brass	Brass	Brass	Brass
9 Adjusting Screw	Brass	Brass	Brass	Brass	Brass	Brass
10 Handle	Steel	-	Steel	-	Steel	-
Working Pressure	0.1 ~ 40 (kg/cm ²)		0.1 ~ 40 (kg/cm ²)		0.1 ~ 40 (kg/cm ²)	
Working Temperature	-196°C ~ 225°C		-40°C ~ 200°C		-40°C ~ 200°C	

DIMENSIONS

Unit : mm

Size	Orifice	Lift	L1	L2	H1	H2
P1 x P2	D					
1/2 x 3/4	15	1.04	35	53.5	169	144.6
1/2 x 1	15	1.52	39	63	196.5	172.6
3/4 x 1	19	1.52	39	62.5	196	172
1 x 1	21	1.52	39	68	210.5	178
1 x 1-1/4	26	2	52	74.5	215.5	197
1-1/4 x 1-1/2	33	2.56	58.5	88.5	245.5	227
1-1/2 x 2	39	3.04	64.5	100.5	284.5	258
2 x 2	39	3.04	64.5	103.5	287.5	261
2 x 2-1/2	50	4	72	110	303	277

General Note
FVXL-BSS FVX-BSS (with metal-to-metal sealing)
FVGXL-BVS FVGX-BVS (with disc insert Viton)
FVGXL-BTS FVGX-BTS (with disc insert PTFE)

*Specification given are subject to changed without further notice.

SAFETY VALVE FULL LIFT TYPE

STAINLESS STEEL

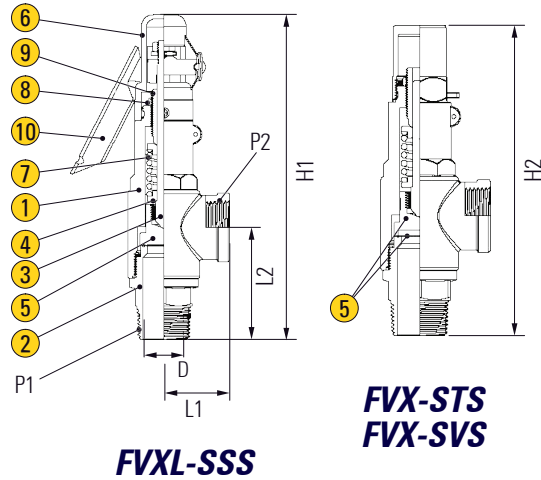

APPLICATION

Suitable for water, steam, oil, gases and non-abrasive media
(Refer to corrosion resistance table for valve materials selection).

SPECIFICATION

End Connection	Male thread inlet Female thread outlet
Adjustment Range	Standard 0.3 to 10 kg/cm ² Up to 110 Bar (optional)
Working Temperature	Up to 350°C
Optional	Lifting lever, Disc with PTFE

MATERIAL

Parts	Material										
	FVXL-SSS with lever, metal-to-metal sealing	FVX-SSS metal-to-metal sealing	FVXL-SVS with lever, disc insert Viton	FVX-SVS disc insert Viton	FVXL-ST/S with lever, disc insert PTFE	FVX-ST/S disc insert PTFE	FVHXL with lever, inlet flange outlet thread	FVFXH inlet flange outlet thread	FVFXL with lever, inlet flange outlet thread	FVFX inlet flange outlet thread	
1 Valve Body	SS304 / SS316	SS304 / SS316	SS304 / SS316	SS304 / SS316	SS304 / SS316	SS304 / SS316	SS304 / SS316	SS304 / SS316	SS304 / SS316	SS304 / SS316	
2 Valve Seat	SS316	SS316	SS316	SS316	SS316	SS316	SS304 / SS316	SS304 / SS316	SS304 / SS316	SS304 / SS316	
3 Spindle	SS304	SS304	SS304	SS304	SS304	SS304	SS304	SS304	SS304	SS304	
4 Spring Seat	SS304	SS304	SS304	SS304	SS304	SS304	SS304	SS304	SS304	SS304	
5 Disc	SS316	SS316	SS316 + Viton	SS316 + Viton	SS316 + PTFE	SS316 + PTFE	SS316	SS316	SS316	SS316	
6 Cap	SS304	SS304	SS304	SS304	SS304	SS304	SS304	SS304	SS304	SS304	
7 Spring	SS304	SS304	SS304	SS304	SS304	SS304	SS304	SS304	SS304	SS304	
8 Nut	SS304	SS304	SS304	SS304	SS304	SS304	SS304	SS304	SS304	SS304	
9 Adjusting Screw	SS304	SS304	SS304	SS304	SS304	SS304	SS304	SS304	SS304	SS304	
10 Handle	SS304	-	SS304	-	SS304	-	SS304	-	SS304	-	
Working Pressure	0.1 ~ 100 (kg/cm ²)		0.1 ~ 50 (kg/cm ²)		0.1 ~ 50 (kg/cm ²)		0.1 ~ 100 (kg/cm ²)		0.1 ~ 100 (kg/cm ²)		
Working Temperature	-196°C ~ 350°C		-40°C ~ 200°C		-40°C ~ 200°C		-196°C ~ 350°C		-196°C ~ 350°C		

DIMENSIONS

Unit : mm

FVXL-SSS ~ FVX-ST/S						
Size	Orifice	Lift	L1	L2	H1	H2
P1 x P2	D					
1/2 x 1	15	1	41	66	200	179
3/4 x 1	20	1.5	41	66	200	179
1 x 1	21	2	41	71	205	183
1-1/4 x 2	33	2.5	65	101	285	261
1-1/2 x 2	39	3	65	101	285	261
2 x 2	39	4	65	104	288	265

DIMENSIONS

Unit : mm

FVHXL ~ FVFX											
Size	Orifice	Lift	FVHXL & FVFXH				FVFXL & FVFX				
			L1	L2	H1	H2	L1	L2	H1	H2	
1/2 x 1/2	15	1	41	66	200	179	84.5	72	203	182	
3/4 x 3/4	20	1.5	41	72	-	183	-	72	203	-	
3/4 x 1	20	1.5	41	72	200	-	84.5	-	-	182	
1 x 1	21	2	41	77	205	183	99	77	210	187	
1-1/4 x 1-1/4	33	2.5	65	101	285	261	128	106	289	265	
1-1/2 x 1-1/2	39	3	65	101	285	261	135	107	290	266	
2 x 2	39	4	65	104	288	265	321	293	293	268	

*Specification given are subject to changed without further notice.

PRESSURE REDUCING VALVE SCREW END

CAST IRON / STAINLESS STEEL

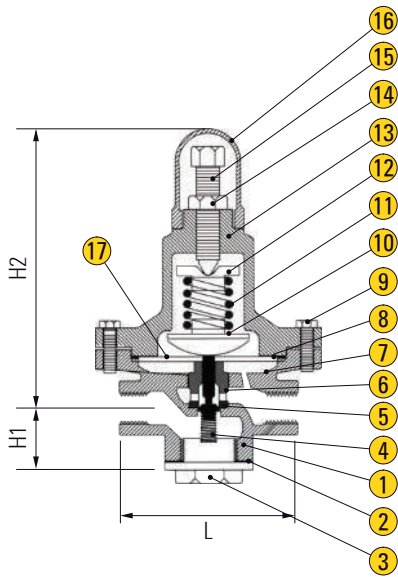

Cast Iron

CF8

APPLICATION

Suitable for water, steam, oil, gases and non-abrasive media
 (Refer to corrosion resistance table for valve materials selection).

SPECIFICATION

Spring Range	1 to 6 Barg adjustable
Pressure Rating	10 Bar
Working Temperature	Up to 200°C
End Connection	Screwed end BSPT

MATERIAL

Parts	Cast Iron	Stainless Steel
1 Body	Cast Iron	CF8
2 Gasket	Asbestos	Asbestos
3 Bottom Plug	Cast Iron	CF8
4 Bottom Spring	SUP-6	SUP-6
5 Spring Knob	PTFE	PTFE
6 Stem	CF8	CF8
7 Stem Guide	CF8	CF8
8 Gasket	Asbestos	Asbestos
9 Bolt	SS41	CF8
10 Spring Knob	SS41	SS41
11 Top Spring	SUP-6	SUP-6
12 Spring Holder	SS41	SS41
13 Top Ud	Cast Iron	CF8
14 Positioning Nut	SS41	CF8
15 Adjusting Screw	SS41	CF8
16 Top Cap	Cast Iron	CF8
17 Diaphragm Disc	AIS-301	AIS-301

DIMENSIONS

Unit : mm

Size		L	H1	H2	Weight (Kg)
mm	Inch				
15	1/2	95	55	185	4
20	3/4	95	55	185	4.2
25	1	95	55	185	4.4
32	1-1/4	130	72	205	6.5
40	1-1/2	130	72	205	7
50	2	168	90	260	13

*Specification given are subject to changed without further notice.

PRESSURE REDUCING VALVE FLANGE END

CAST IRON / CAST STEEL / STAINLESS STEEL

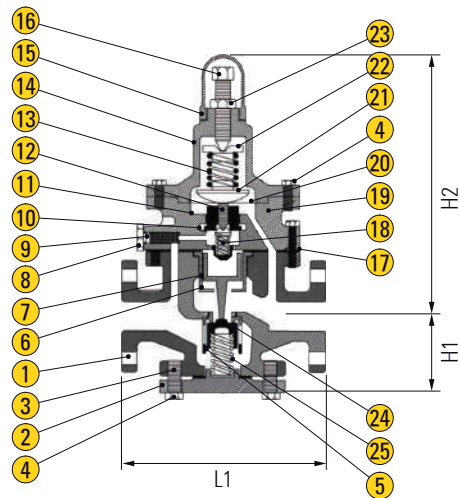

APPLICATION

Suitable for water, steam, oil, gases and non-abrasive media
(Refer to corrosion resistance table for valve materials selection).

SPECIFICATION

Spring Range	1 to 6 Barg adjustable
Pressure Rating	10 Bar
Working Temperature	Up to 200°C
End Connection	Flanged end to ANSI 150, JIS10K and PN16

MATERIAL

Parts	Cast Iron	Stainless Steel
1 Main Body	Cast Iron	SUS304
2 Bottom Cover	Cast Iron	SUS304
3 Gasket	Asbestos	Asbestos
4 Bolt	SS41	SUS304
5 Valve Seat	CF8	CF8
6 Cylinder	CF8	CF8
7 Piston	CF8	CF8
8 Stinger Plug	SS41	SUS304
9 Screen	SS304	SUS304
10 Spring Knob	SUS304	SUS304
11 Pin Guide	SUS304	SUS304
12 Floating Pin	SUS304	SUS304
13 Upper Spring	SUP-6	SUP-6
14 Top Ud	Cast Iron	SUS304
15 Top Cap	Cast Iron	SUS304
16 Adjusting Screw	SS41	SUS304
17 Body Gasket	Asbestos	Asbestos
18 Setral Spring	SUS304	SUS304
19 Transit Body	Cast Iron	SUS304
20 Diaphragm Disc	AIS-301	AIS-301
21 Spring Knob	SS41	SS41
22 Spring Holder	SS41	SS41
23 Positioning Nut	SS41	SUS304
24 Gasket	PTFE	PTFE
25 Lower Spring	SUP-6	SUP-6

DIMENSIONS - ANSI 150LB / JIK10K / PN16-DIN-2633

Unit : mm

Size		L		H1	H2	Weight (Kg)
mm	Inch	CI	CF8			
15	1/2	155	158	74	260	10
20	3/4	155	158	74	260	10.5
25	1	165		74	260	11
32	1-1/4	195		99	280	16
40	1-1/2	195		99	280	17
50	2	225		116	310	24
65	2-1/2	250		125	322	31
80	3	290		135	325	37
100	4	330		153	370	50
125	5	410		195	540	98
150	6	410		195	540	105

*Specification given are subject to changed without further notice.

PRESSURE REDUCING VALVE FLANGE END

DUCTILE IRON / CAST IRON / STAINLESS STEEL

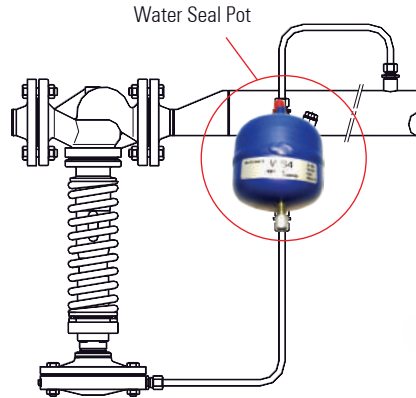
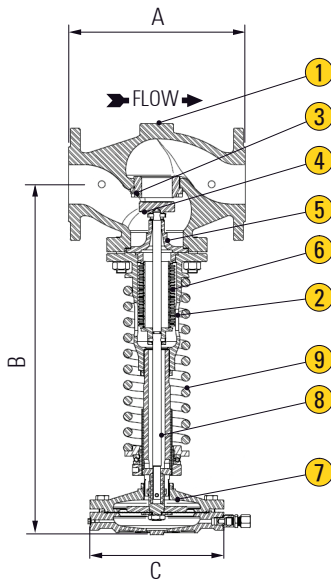

Cast Iron / Cast Steel



Stainless Steel

APPLICATION

Suitable for water, steam, oil, gases and non-abrasive media
(Refer to corrosion resistance table for valve materials selection).

SPECIFICATION

Spring Range	1 to 25 Barg adjustable
Pressure Rating	40 Bar
Working Temperature	Up to 250°C
End Connection	Flanged end to ANSI 150, JIS10K and PN16

MATERIAL

Parts	Material	
1	Valve Body RP45G	GJS-400-15 / 0.7040
	Valve Body RP45S	A216WCB / 1.0619
	Valve Body RP45I	CF8M / 1.4408
2	Piston Body RP45G and PR45S	GJS-400-15 / 0.7040
	Piston Body RP45I	GJS-400-15 / 0.7040 Nickel plated
3	Valve Seat	Stainless Steel
4	Valve Disc *	Hardened Stainless Steel
	Soft Valve Disc *	AISI 304 / 1.4301; NBR (PTFE/GR, etc.)
5	Guide	Bronze B62 / ASTM B148-97
6	Bellows *	AISI 316 Ti / 1.4571
7	Diaph. Chamber RP45G *	GJL-250 / 0.6025
	Diaph. Chamber RP45S *	A216WCB / 1.0619
	Diaph. Chamber RP45I *	CF8M / 1.4408
8	Spindle	AISI 304 / 1.4301
9	Regulating Spring	Spring steel

* Available spare parts.

DIMENSIONS

Unit : mm

Size (DN)	Valve			Actuator	
	A	B	Weight (Kg)	C	Weight (Kg)
15	130	440	12.7	172	4.3
20	150	440	12.7	172	4.3
25	160	440	13.7	172	4.3
32	180	445	15.7	172	4.3
40	200	445	17.7	172	4.3
50	230	540	25.7	220	7.3
65	290	540	29.7	220	7.3
80	310	610	36.7	282	11.3
100	350	650	53.7	340	16.3
125	400	780	101.4	172	4.4
150	480	790	134.5	220	7.4

*Specification given are subject to changed without further notice.

PRESSURE REDUCING VALVE PILOT OPERATED CAST STEEL

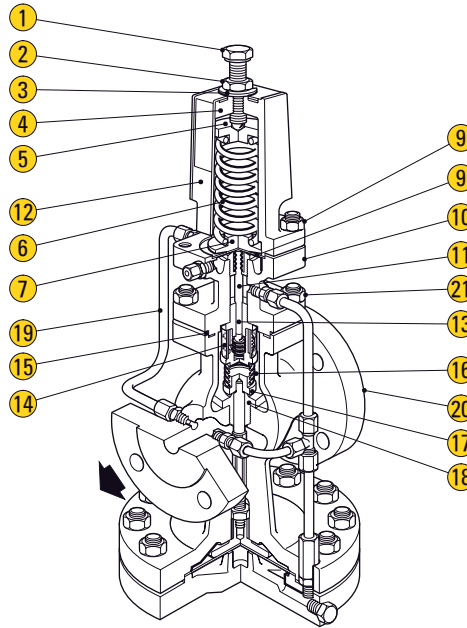

APPLICATION

Suitable for water, steam, oil, gases and non-abrasive media
(Refer to corrosion resistance table for valve materials selection).

SPECIFICATION

Spring Range	1 to 160 Barg adjustable
Pressure Rating	240 Bar
Working Temperature	Up to 425°C
End Connection	Flanged end to ANSI 150, 300 and 600, PN16, PN40 and PN64

MATERIAL

Parts	Material	Parts	Material
1 Adjustment Screw	Steel BS 3692 Gr. 8.8	13 Pilot Valve and Seat Unit	S. Steel BS 970 431 S29
2 Adjustment lock-nut	Steel BS 3692 Gr. 8	14 Internal Strainer	S. Steel BS 1449 304 S16
3 Washer	S. Steel BS 1449 304 S16	15 Body Gasket	Stainless Steel Reinforced Exfoliated Graphite
4 Spring Housing	Cast Steel DIN 17245 GS C25	16 Main Valve Return Spring	S. Steel BS 2056 302 S16
5 Top Spring Plate	S. Steel BS 970 220 Mo7	17 Main Valve	S. Steel BS 970 431 S29
6 Pressure Adjustment Spring	S. Steel BS 2056 302 S25	18 Main Valve Seat	S. Steel BS 970 431 S29
7 Bottom Spring Plate	Steel BS 970 220 Mo7	19 Balance Pipe Assembly	S. Steel BS 3605 304 S14
8 Spring Housing	Securing Nuts Steel BS 3692 Gr. 8	20 Main Valve Body	Cast Steel DIN 17245 GS C25
9 Pilot Diaphragm	S. Steel BS 1449 316 S31	21 Pilot Valve Housing	Securing Nuts Steel BS 3692 Gr. 8 Securing Studs Steel BS 4439 Gr. 8.8
10 Pilot Valve Housing	Steel		
11 Pilot Valve Plunger	S. Steel BS 970 431 S29		
12 Spring Housing Cover	S. Steel BS 1449 304 S12		

DIMENSIONS

Unit : mm

Size (DN)	External Dimension						
	L			H	H1	H	H1
	PN 16/25 ANSI 150	PN 40 ANSI 300	PN 64 ANSI 600	PN 16/25/40 ANSI 150/300		PN 64 ANSI 600	
15	160	180	180	295	90	305	100
20	160	180	180	330	98	340	105
25	180	200	200	330	110	340	120
32	200	220	220	330	110	340	120
40	220	240	240	345	125	355	135
50	250	270	270	345	125	355	135
65	280	300	300	350	130	360	140
80	310	330	330	385	160	395	170
100	350	380	380	385	170	400	185
125	400	450	450	400	200	415	215
150	450	500	500	415	210	430	225
200	500	550	550	475	240	495	260
250		650		525	290	545	310
300		800		580	335	600	355

*Specification given are subject to changed without further notice.

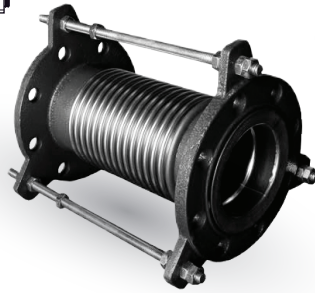
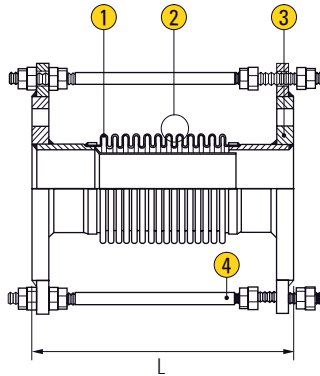

Available Upon Request :

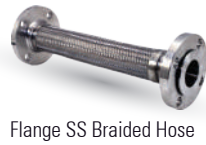

APPLICATION

Suitable for water, steam, oil, gases and others non-abrasive media (Refer to corrosion resistance table for valve materials selection).

SPECIFICATION

Size Range	15mm to 600mm (1/2" to 24")
Material	Stainless steel ASIS 321
Connection	Welding end, Flanged end to DIN ANSI B16.5 and JIS standards
Working Pressure	Up to 45 Bar
Working Temperature	Up to 400°C

MATERIAL

Parts	Material
1 Bellows	SUS304 / SUS316
2 Internal Sleeve	SUS304 / SUS316
3 Flange	SS400 / SUS304 / SUS316
4 Limit Rods	S25C / SUS304 / SUS316

DIMENSIONS

Unit : mm (inch)

Nominal Bore	Total Length	Bellows			Axial Movement	Working Pressure		Axile Spring Plate (N/mm)	Effective Area	
		O.D.	Corr. (no.)	PLY (no.)		Bar	PSI		cm ²	Inch ²
15 (1/2)	300 (9.84)	25 (0.98)	36	1	32 (1.25)	10	145.2	10.96	3.6	0.6
	350 (13.78)		52			25	363		8.72	3.5
20 (3/4)	300 (9.84)	32.5 (1.28)	31	1	32 (1.25)	10	145.2	16.17	5.9	0.9
	350 (13.78)		46			25	363		13.23	5.9
25 (1)	300 (9.84)	38 (1.50)	28	1	32 (1.25)	10	145.2	31.26	8.4	1.3
	350 (13.78)		40			25	363		14.41	8.4
32 (1-1/4)	300 (9.84)	48.0 (1.91)	36	1	50 (2)	10	145.2	17.93	13.2	2.0
	350 (13.78)		2			25	363		19.01	13.8
40 (1-1/2)	300 (9.84)	58.0 (2.30)	32	1	50 (2)	10	145.2	22.44	20.2	3.1
	350 (13.78)		2			25	363		28.91	20.2
50 (2)	300 (9.84)	75.0 (2.99)	24	1	50 (2)	10	145.2	18.42	32.8	5.1
	350 (13.78)		2			25	363		44.10	32.1
65 (2-1/2)	300 (9.84)	90.0 (3.58)	20	1	50 (2)	10	145.2	45.37	49.6	7.7
	350 (13.78)		2			25	363		89.57	49.1
80 (3)	300 (9.84)	104.0 (4.13)	20	1	50 (2)	10	145.2	45.08	67.8	10.5
	350 (13.78)		2			25	363		81.34	67.4
100 (4)	300 (9.84)	130.0 (5.20)	16	1	50 (2)	10	145.2	47.82	108.0	16.7
	350 (13.78)		2			25	363		145.73	108.9
125 (5)	300 (9.84)	160.0 (6.42)	15	1	50 (2)	10	145.2	84.87	166.5	25.8
	350 (13.78)		2			25	363		160.72	167.1
150 (6)	300 (9.84)	194.0 (7.64)	14	1	50 (2)	10	145.2	78.99	232.4	36.0
	350 (13.78)		2			25	363		192.37	239.2
200 (8)	300 (9.84)	252.0 (9.92)	13	1	50 (2)	10	145.2	136.42	394.1	61.1
	350 (13.78)		2			25	363		263.52	420.9
250 (10)	300 (9.84)	313.0 (12.40)	12	1	50 (2)	10	145.2	179.63	589.7	91.4
	350 (13.78)		2			25	363		427.97	664.6
300 (12)	300 (9.84)	360.0 (14.29)	12	1	50 (2)	10	145.2	183.95	829.6	128.6
	350 (13.78)		2			25	363		498.62	925.4

Note : Other movements, sizes, pressure, material expansion joints are available on request

*Specification given are subject to changed without further notice.

EXPANSION JOINT

GIMBAL TYPE / EXTERNAL PRESSURIZED TYPE

STAINLESS STEEL



Gimbal Type



External Pressurized Type

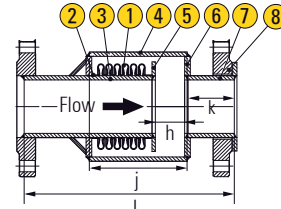
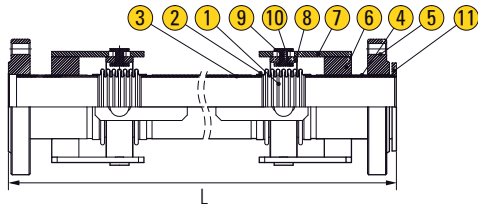

APPLICATION

Suitable for water, steam, oil, gases and others non-abrasive media
(Refer to corrosion resistance table for valve materials selection).

SPECIFICATION

Size Range
Material
Connection
Working Pressure
Working Temperature

25mm to 600mm (1" to 24")
Stainless steel AISI 321
Welding end, Flanged end to DIN, ANSI B16.5 and JIS standards
Up to 45 Bar
Up to 400°C

MATERIAL - GIMBAL TYPE

Parts	Material
1 Bellow	AISI 304
2 Band	AISI 304
3 Intermediate Pipe	St. 37.2
4 Butt Weld	St. 37.2
5 Flange	St. 37.2
6 Short Blade	St. 37.2
7 Long Blade	St. 37.2
8 Gimbal	St. 37.2
9 Gib	St. 37.2
10 Washer	St. 37.2
11 Collar	St. 37.2

MATERIAL - EXTERNAL PRESSURIZED TYPE

Parts	Material
1 Bellow	AISI 304
2 Band	AISI 304
3 Inner Pipe	St. 37.2
4 Outer Pipe	St. 37.2
5 Centering Flange	St. 37.2
6 Outer Pipe Flange	St. 37.2
7 Butt Weld	St. 37.2
8 Flange	St. 37.2

DIMENSIONS - GIMBAL TYPE

Unit : mm

Size (DN)	Movement			100 KMF			300 KMF			400 KMF			
	±X	±Y	±Z	L	±Y	±Z	L	±Y	±Z	L	±Y	±Z	L
25	50	50	50	720	100	100	920	150	150	1120	200	200	1320
32	50	50	50	720	100	100	920	150	150	1120	200	200	1320
40	50	50	50	720	100	100	920	150	150	1120	200	200	1320
50	50	50	50	800	100	100	1000	150	150	1200	200	200	1420
65	50	50	50	800	100	100	1000	150	150	1250	200	200	1500
80	50	50	50	830	100	100	1030	150	150	1270	200	200	1500
100	50	50	50	850	100	100	1050	150	150	1300	200	200	1550
125	50	50	50	980	100	100	1180	150	150	1480	200	200	1780
150	50	50	50	980	100	100	1180	150	150	1480	200	200	1780
200	50	50	50	1140	100	100	1340	150	150	1700	200	200	2050
250	50	50	50	1140	100	100	1340	150	150	1700	200	200	2100
300	50	50	50	1200	100	100	1400	150	150	1760	200	200	2106

DIMENSIONS - EXTERNAL PRESSURIZED TYPE

Unit : mm

Size (DN)	Design Pressure : PN16 Axial Movement : -20mm + 10				Design Pressure : PN16 Axial Movement : -40mm + 20				Design Pressure : PN16 Axial Movement : -70mm + 20			
	h	k	j	L	h	k	j	L	h	k	j	L
25	30	80	180	360	50	80	300	490	80	80	300	520
32	30	80	180	360	50	80	300	490	80	80	300	520
40	30	80	200	380	50	80	310	500	80	80	310	530
50	30	80	190	370	50	80	290	480	80	80	290	510
65	30	80	190	370	50	80	280	470	80	80	280	500
80	30	80	190	370	50	80	280	470	80	80	280	500
100	30	80	200	380	50	80	290	480	80	80	290	510
125	30	80	180	380	50	80	290	490	80	80	290	520
150	30	80	210	400	50	80	310	510	80	80	310	540
200	30	80	200	420	50	80	300	530	80	100	300	560
250	30	80	210	440	50	80	300	540	80	100	300	570
300	30	80	230	460	50	80	330	570	80	100	330	600

*Specification given are subject to changed without further notice.

STEAM TRAP

THERMODYNAMIC TYPE

CAST IRON / FORGED STEEL / STAINLESS STEEL

HELS
HOSE-EXPANSION JOINT-LEVEL CONTROL-STEAM TRAP

ESCO
Steam Traps

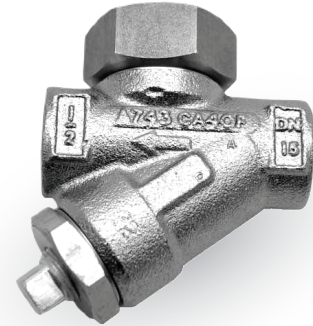
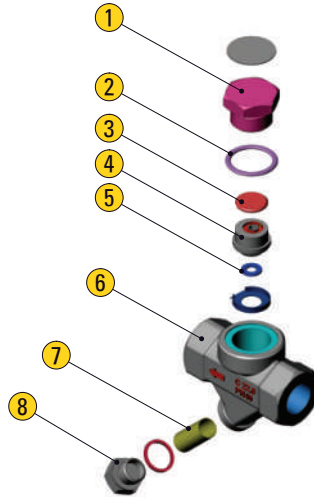
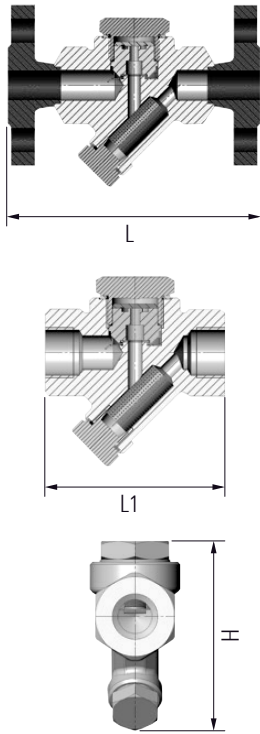

APPLICATION

Suitable for steam
(Refer to corrosion resistance table for valve materials selection).

SPECIFICATION

Size Range	1/4" to 2"
Body Material	Cast Iron, Ductile Iron, Forged steel, Stainless Steel
Pressure Rating	Up to 45 Bar
Working Temperature	Up to 425°C
Connection	Threaded, Socket weld, Flanged end

MATERIAL

Parts	Material
1 Cover	Cadmium Coated St.37
2 Cover Gasket	Stainless Steel AISI 304
3 Disc	Stainless Steel AISI 420
4 Seat	Stainless Steel AISI 420
5 Seat Gasket	Stainless Steel AISI 304
6 Body	Cast Iron / Forged Steel - A105N / Stainless Steel - F316
7 Strainer Screen	Stainless Steel AISI 304
8 Discharge Bolt	Stainless Steel AISI 304

DIMENSIONS

Unit : mm

Size (DN)	Flanged	Threaded	H
	L	L1	
15	150	95	60
20	150	95	60
25	160	95	60
32	205	170	115
40	205	170	115
50	240	200	120

*Specification given are subject to changed without further notice.

STEAM TRAP BALL FLOAT TYPE

CAST IRON / DUCTILE IRON /
CAST STEEL / STAINLESS STEEL

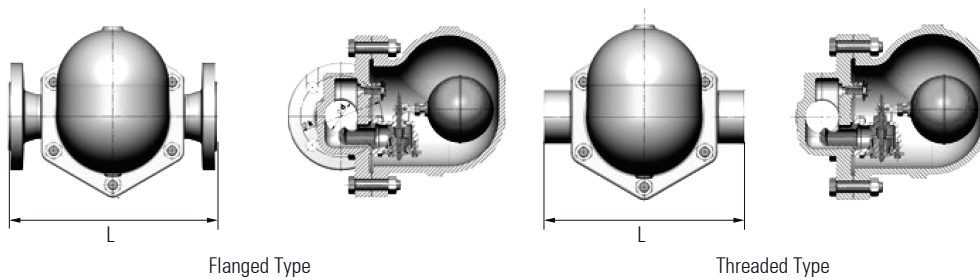
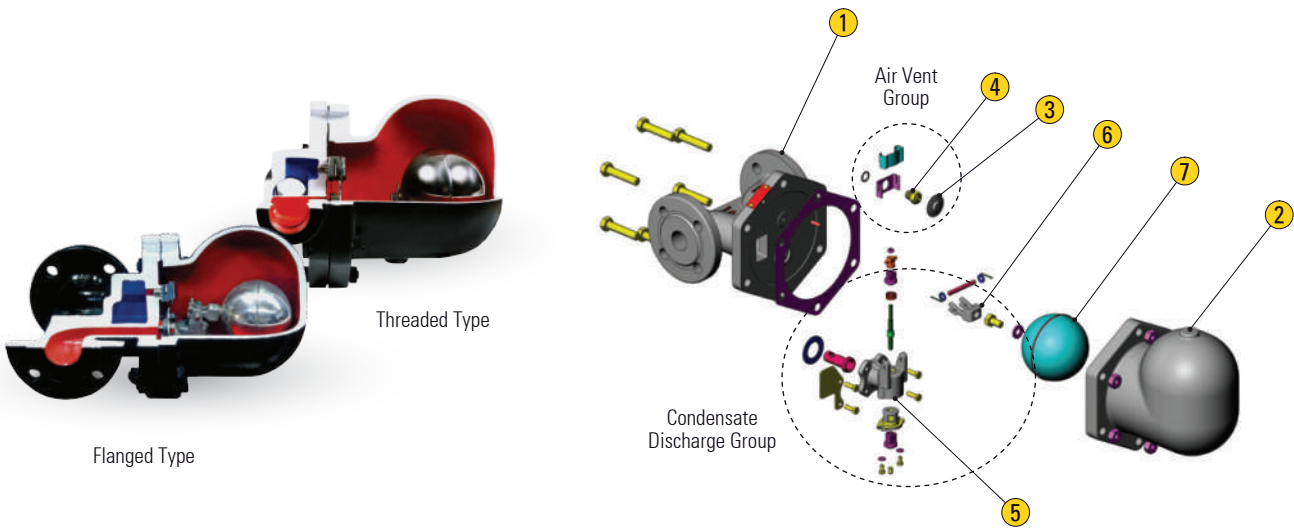

APPLICATION

Suitable for steam
(Refer to corrosion resistance table for valve materials selection).

SPECIFICATION

Size Range	1/2" to 4"
Body Material	Cast Iron, Ductile Iron, Cast steel
Pressure Rating	Up to 32 Bar
Working Temperature	Up to 450°C
Connection	Threaded end , Flanged end

MATERIAL

Parts	Material
1 Body	GGG 40.3 / GSC 25 / Stainless Steel
2 Cover	GGG 40.3 / GSC 25 / Stainless Steel
3 Thermostatic Capsule	Stainless Steel
4 Air Vent Seat	Stainless Steel AISI 304
5 Valve Assembly	Stainless Steel
6 Float Lever	Stainless Steel AISI 304
7 Float	Stainless Steel AISI 304

DIMENSIONS

Unit : mm

Size (DN)	Flanged	Threaded
	L	L
15	150	122
20	150	122
25	160	145
32	320	270
40	320	270
50	320	300

*Specification given are subject to changed without further notice.

STEAM TRAP INVERTED BUCKET TYPE

CAST IRON / DUCTILE IRON /
CAST STEEL / STAINLESS STEEL

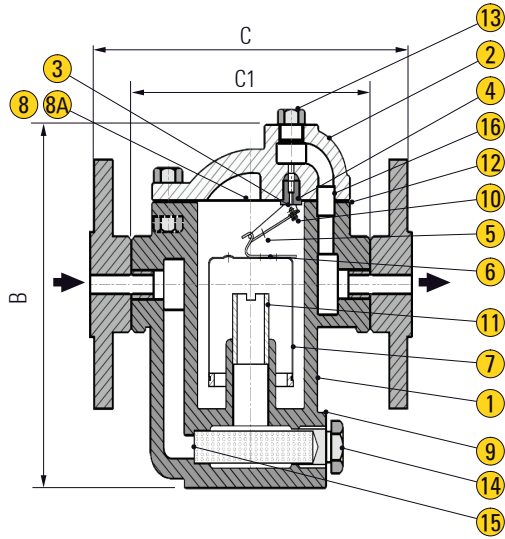

APPLICATION

Suitable for steam
(Refer to corrosion resistance table for valve materials selection).

SPECIFICATION

Size Range	1/2" to 2-1/2"
Body Material	Cast Iron, Ductile Iron, Cast steel, Stainless Steel
Pressure Rating	Up to 64 Bar
Working Temperature	Up to 425°C
Connection	Threaded, Socket weld, Flanged end

MATERIAL

Parts	Material
1 Bonnet	CI ASTM A48 Class 30
2 Body	CI ASTM A48 Class 30
3 Valve	Chrome Steel
4 Valve Seat	Chrome Steel
5 Lever	SS304
6 Bucket Clip	SS304
7 Bucket	SS304
8 Guide Pin Plate	SS304
8A Guide Pin	SS304
9 Strainer Gasket	Steel
10 Valve Clip	SS304
11 Internal Tube	Steel Pipe
12 Gasket	SS304 + Graphite
13 Bonnet Plug	Steel
14 Strainer Plug	Steel
15 Screen	SS304
16 Thimble	SS304

DIMENSIONS

Unit : mm

Size (DN)	B	Flanged	Threaded
		C	C1
15	153	128	195
20	181	128	195
25	228	174	229
32	314	211	261
40	349	232	355
50	413	258	398

*Specification given are subject to changed without further notice.

STEAM TRAP

RANGE AND OTHER STEAM PRODUCTS

APPLICATION

SPECIFICATION

Thermostatic
(Steam Trap)



Product Features:
Reducing flash steam losses. Operation under back pressure more than 80% of inlet pressure. High resistance against water hammer. Easy maintenance.

Typical Applications:
Tracing lines, Iron, Heating equipment, Presses

Size Range 1/2" to 4"
Pressure Rating Up to 32 Bar
Working Temperature Up to 200°C / 250°C

Bimetallic
(Vacuum Breakers)



Product Features:
Reducing flash steam losses. Energy Saving. Good air venting. High resistance against water hammer.

Typical Applications:
Tracing lines, Turbines, Marine applications, Presses, Oven

Size Range 1/2" to 2"
Pressure Rating Up to 32 Bar
Working Temperature Up to 400°C

Thermostatic
(Vacuum Breakers)



Product Features:
Automatically relieving or breaking unwanted vacuum condition, restoring the atmospheric pressure. Brass or stainless steel body.

Typical Applications:
Heat exchangers, Heating coils, Calorifiers, Jacketed kettles, Steam boilers

Size Range 1/2"
Pressure Rating Up to 16 Bar (Brass) / 25 Bar (Stainless Steel)
Working Temperature Up to 260°C (Brass) / 400°C (Stainless Steel)

Thermostatic
(Air Eliminators)



Product Features:
Modulating discharge. Discharge condensate close to steam temperature.

Typical Applications:
Process equipment, Kettle cookers, Sterilizers, Food, chemical and laundry equipment

Size Range 1/4" to 1/2"
Pressure Rating Up to 10 Bar
Working Temperature Up to 150°C

Float Type
(Air Eliminators)



Product Features:
Removing air from HVAC systems and is also suitable for non corrosive and/or dangerous liquids. Corrosion-resistant working units.

Typical Applications:
Cold and hot water systems, Air elimination and separation systems.

Size Range 1" to 2"
Pressure Rating Up to 16 Bar
Working Temperature Up to 200°C / 250°C

Float Type
(Liquid Drainers)



Product Features:
Modulating discharge. Unaffected by sudden or wide load any pressure changes.

Typical Applications:
Aftercoolers, Separators, Compressed air and gas mains

Size Range 1/2" to 2"
Pressure Rating Up to 16 Bar
Working Temperature Up to 250°C

Steam Separator
(Special Equipment)



Product Features:
Removing moisture from steam and compressed air pipelines.

Typical Applications:
Saturated and superheated steam lines

Size Range 1/2" to 12"
Pressure Rating Up to 16/25/40 Bar
Working Temperature Up to 200°C

BLOW DOWN VALVE PARALLEL SLIDE TYPE BRONZE / CAST STEEL

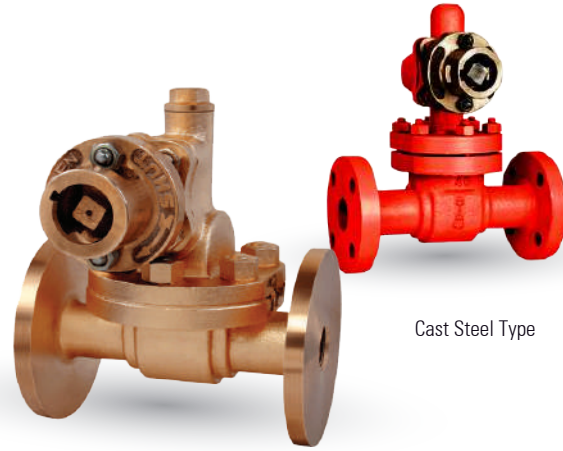
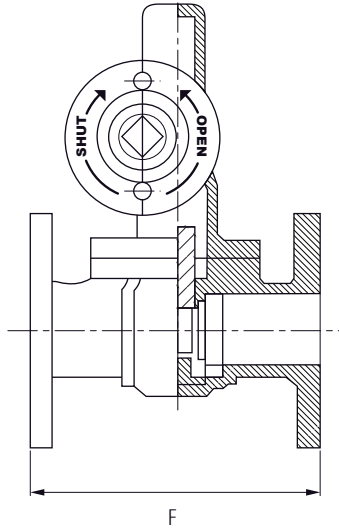

Bronze Type

Cast Steel Type

APPLICATION

Suitable for steam
 (Refer to corrosion resistance table for
 valve materials selection).

SPECIFICATION

Size Range	1" to 3"
Body Material	Cast Steel, Bronze
Pressure Rating	Up to 25 Bar
Working Temperature	Up to 400°C
Connection	Flanged end to ANSI 150 and 300, PN16 and PN40

MATERIAL

Parts	Bronze	Cast Steel
1 Body	IBR Bronze Gr.B	Cast Carbon Steel
2 Bonnet		
3 Stuffing Box		
4 Gland	IBR Bronze Gr.B	Bronze
5 Rack & Pinion		
6 Body Seat & Valve Disc	Cast Monel	Cast Monel
7 Spring	Spring Steel	Spring Steel
8 Gasket	Compressed Asbestos Fibre	Compressed Asbestos Fibre
9 Gland Packing	Graphited Asbestos	Graphited Asbestos
10 Operating Key	Mild Steel	Mild Steel

DIMENSIONS

Unit : mm

Size (DN)	Bronze	Cast Steel
	F	F
25	174.5	178.0
32	178.0	242.0
40	190.5	267.0
50	206.5	305.0
65	288.5	330.0

*Specification given are subject to changed without further notice.

BLOW DOWN VALVE

RAPID ACTION / INTERMITTENT TYPE

CAST STEEL



Actuator and Manual Operation Type
(*available on request)

Manual Operation Type

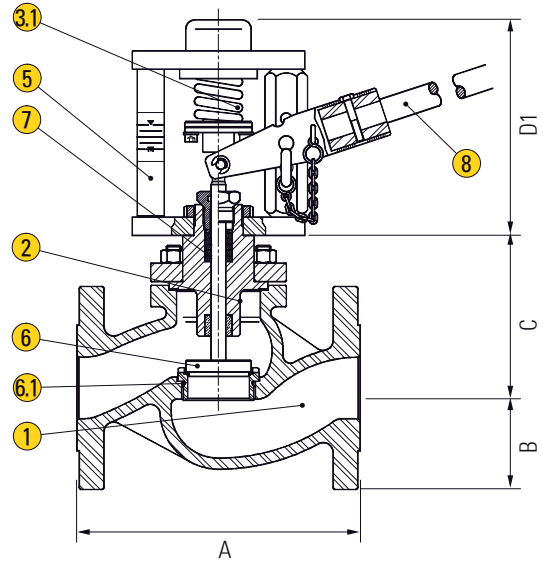

APPLICATION

Suitable for steam
(Refer to corrosion resistance table for valve materials selection).

SPECIFICATION

Size Range	3/4" to 2"
Body Material	Cast steel
Pressure Rating	Up to 25 Bar
Working Temperature	Up to 400°C
Connection	Flanged end to ANSI 150 and 300, PN16 and PN40

MATERIAL

Parts	Material
1 Valve Body	A216 WCB / 1.0619
2 Bonnet	CF8 / 1.4038
3 Actuator *	Steel Fe410.1 / St. Steel
3.1 Spring *	Spring Steel
4 Diaphragm *	NBR 70
5 Yoke	Carbon Steel / St. Steel
6 Valve Plug *	Hardened St. Steel
6.1 Valve Seat *	Hardened St. Steel
7 Packing	Graphite
8 Valve Lever	Stainless Steel / 1.4301

* Available spare parts.

DIMENSIONS - VALVE BODY

Unit : mm

Size (DN)	A	B	C	D1	* Weight (Kg)	** Weight (Kg)
20	150	53	80	175	15	12
25	160	58	85	175	16	13
32	180	70	90	175	20	17
40	200	75	95	175	25	22
50	230	83	105	175	24	31

Note : * Valve with pneumatic actuator, ** Valve with manual lever only

*Specification given are subject to changed without further notice.